



# BLOWERS

AAKASH ENGINEERING WORKS

An ISO 9001 : 2015 Certified Company

Positive Displacement Blower & Vacuum System

*We Produce The Shape Of Progress*



100%  
Oil Free  
Air



**MSME**

MICRO, SMALL & MEDIUM ENTERPRISES

सूक्ष्म, लघु एवं मध्यम उद्यम

OUR STRENGTH • हमारी शक्ति

Ministry of MSME, Govt. of India

AEW Blowers is a highly reputable company specializing in the manufacturing & distribution of high quality root blowers along with its spares & accessories. With over 4 decades of industry experience of our director, we have established ourselves in 2007, supplying root blowers, its spare parts & their standard accessories that meet the diverse needs of various industries.

Our state-of-the-art manufacturing facility is equipped with latest CNC, VMC machines & operated by a team of skilled engineers & technicians. We adhere to stringent quality control processes to ensure that every root blower manufactured adheres to the highest standards of quality, reliability & performance.

At AEW, we offer a comprehensive range of root blowers designed for various applications, including wastewater treatment pneumatic conveying, aeration & more. Our products are known for their energy efficiency, durability & low maintenance requirements providing our customers with long-term cost saving and peace of mind.

In addition to designing & manufacturing root blowers, we also provide expert technical support, ensuring that our customers receive personalized assistance & guidance throughout the purchase and installation process. Our dedicated customer service team is available to address any inquiries, offer troubleshooting assistance & provide after-sales support.

We take pride in our commitment to sustainability & environmental responsibility. Our root blowers are designed to minimize energy consumption & reduce carbon footprints, contributing to cleaner and greener future.

As a customer-centric company, we value long-term partnerships & strive to build strong relationships with our clients. We prioritize open communication, prompt delivery & competitive pricing, ensuring that our customers receive exceptional value with every purchase.

At AEW, we are continuously investing in research & development to innovate & stay ahead of industry trends. Our goal is to remain at the forefront of the root blower manufacturing sector by offering reliable, efficient & environmental friendly solutions.

Whether you require a standard root blower or a customized solution tailored to your specific needs, AEW is the trusted choice. Experience our expertise, quality products & top-notch customer service for all your root blower requirements.



### VISION

To be recognized as a leading provider of root blowers globally, known for our innovative solutions, superior quality & dedication to customer satisfaction. We aim to continuously improve & expand our product range, while fostering strong partnerships with customers, suppliers & employees that drive mutual growth & prosperity. Our vision also includes promoting sustainability & embracing technological advancements to help shape a cleaner and greener future.



### MISSION

To provide high-quality, reliable & efficient root blowers that meet the needs of our customers & contribute to their success. We are committed to delivering exceptional products & unparalleled customer service while ensuring sustainability & environmental responsibility.



### VALUES

- Customer focus
- Sincerity at workplace
- Respect for individuals
- Institution building thru skill enhancement
- Transparent communication channels
- Ethics & integrity to know what is right act responsibility our clients colleagues & community.

## SOME OF OUR ESTEEMED CLIENTS



IndianOil



OCEAN INFRA  
WE BELIEVE IN CUSTOMER SATISFACTION



SHREYA  
LIFE SCIENCES



RELAXO



Hindustan Unilever Limited

GAURS  
your own world



Dedicated to Global Healthcare



## ADVANTAGES

- In-house blower design & manufacturing capabilities with most state-of-the-Art facilities with most modern techniques & Technology.
- **In our blower design, the shaft size is larger than usually used in other make blowers.**
- Alloy steel shaft to avoid bending issues & premature failure due to overheat.
- **Both side oil designs give better lubrication & effective cooling.**
- The clearances between lobes and lobe-side plates are designed with precise design calculations to minimize slippage & enhance the efficiency of the machine.
- All parts are machined in the highly precise CNC machines from both inner & outer faces to get maximum efficiency. It also helps to prevent the frictional heat & reduces the running wear & tear. It increases the overall life of the blower.
- All parts are assembled only on Hydraulic-Press machines which increases assembling accuracy & long life of parts.
- We have certified In-house testing facilities as per BS 1571 Part II.
- All rotor shafts assemblies Dynamically Balanced to Gr 6.3 ISO 1940/1 (1986).
- Every Blower is tested in accordance to Standard Test Procedure (STP01) Based on BS 1571 before dispatch.
- We have Decades of experience in design & manufacturing of blowers for well known brands in India.
- Our motto is to provide highest quality products at the most reasonable cost with the long term reliability to our customers.

Root blowers, also known as rotary lobe blowers or positive displacement blowers, are devices used to deliver a continuous flow of air or gas at a fixed pressure. They are commonly used in various industrial applications, such as waste water treatment plants, pneumatic conveying systems & power generation. The design of a root blower consists of two counter-rotating lobed rotors within a housing. The rotors have a unique shape that allows them to trap & transport air or gas from the inlet to the outlet of the blower. As the lobes rotate, they create chambers that draw in and compress the air or gas, resulting in a pulsation-free flow. In waste water treatment plants, root blowers are commonly employed for aeration processes, such as in activated sludge systems. The blowers supply oxygen to the micro-organisms responsible for breaking down organic matter in the waste water. They also assist in maintaining the required mixing & agitation in the treatment tanks.

When selecting a root blower, factors such as required airflow rate, pressure, temperature & gas composition should be considered. Proper maintenance, including regular lubrication & inspection, is essential to ensure the efficient & long-lasting operation of these blowers.

## CUT-SECTION DETAILS

### Extended Bearing Support

First in Industry-Additional Bearing Support in the pulley side oil cover to provide extended support & durability to shaft against bending issues.

### Seals

Lowest-wear & tear, non contacting labyrinth type seals ensure high performance and Long life

### Shafts

Rotor Shafts are EN-19 alloy Steel, that allow higher operating pressures and Rotation speed

### Rotors

Made from Cast Iron with stiff design for maximum life. Rotors are manufacture through CNC and 3D machinery control with high precision and accuracy to ensure the highest performance providing with trouble free performance and durability.

### Bearings

All AEW Blowers units are equipped with 100% Genuine SKF Bearings to ensure long life and durability

### Timing Gears

Forged Steel gears with hardened and ground teeth to reduce vibrations and ensures accurate rotor to rotor timings for smooth, Low noise and efficient operations

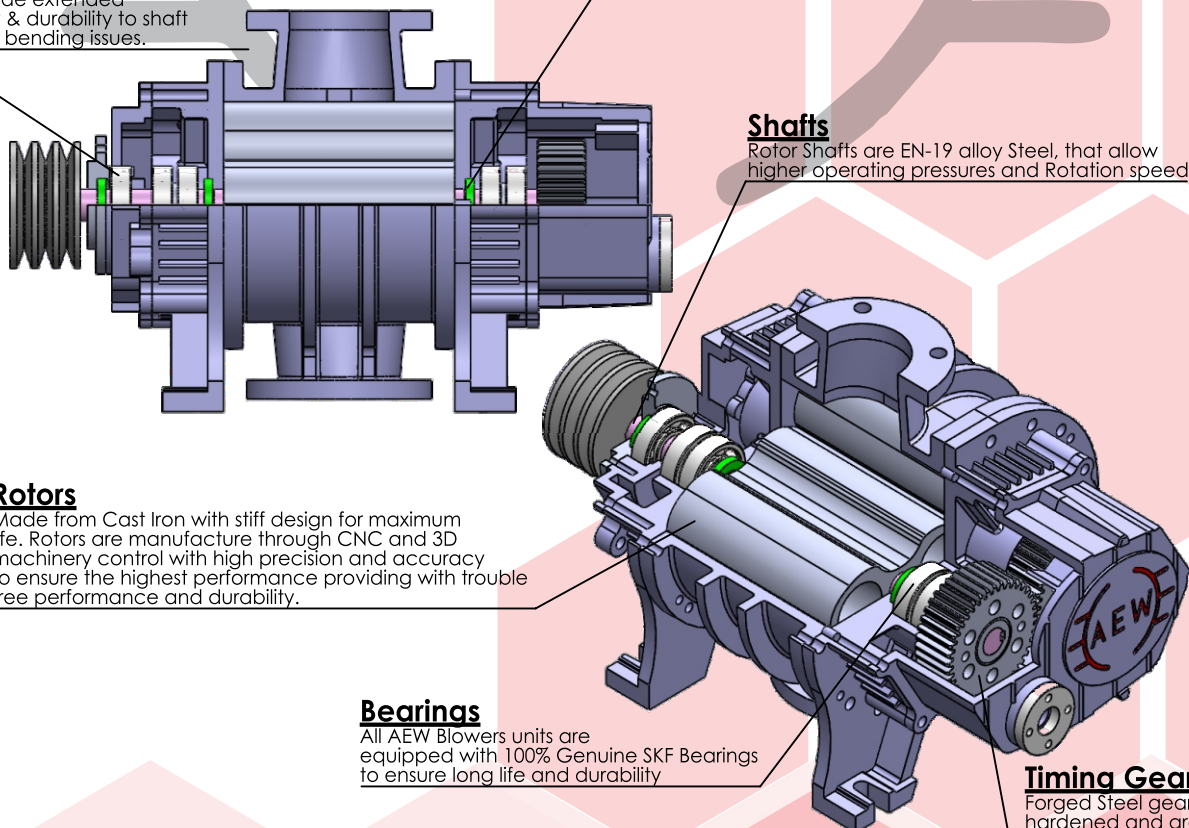

**Our Products**



**Twin Lobe Blower**



**Tri Lobe Blower**



**Water Cooled Blower**



**Direct Drive Blower**



**Gas Blower**



**Pneumatic Conveying Blower**

# AEW BLOWERS

## PERFORMANCE TABLE

MODEL	IN/OUT	SPEED	1000mmwc		2000mmwc		3000mmwc		4000mmwc		5000mmwc		6000mmwc	
			nb	R.P.M	m <sup>3</sup> /hr	BHP	m <sup>3</sup> /hr	BHP	m <sup>3</sup> /hr	BHP	m <sup>3</sup> /hr	BHP	m <sup>3</sup> /hr	BHP
AEW 345	32nb	800	16	0.4	10	0.5	6	0.6	2	0.7				
		1000	23	0.5	17	0.6	13	0.7	9	0.9				
		1200	31	0.6	25	0.7	20	1	17	1.1				
		1400	38	0.7	32	0.8	28	1	24	1.2				
AEW 350	32nb	800	31	0.3	26	0.4	22	0.6	18	0.8	15	0.9	12	1.1
		1000	43	0.4	37	0.6	33	0.8	29	1	26	1.2	24	1.4
		1200	54	0.4	48	0.7	44	0.9	41	1.2	37	1.4	35	1.7
		1400	65	0.5	60	0.8	55	1.1	52	1.4	49	1.7	46	1.9
AEW 365	40nb	800	40	0.3	33	0.6	27	0.8	22	1	18	1.2	14	1.4
		1000	55	0.4	47	0.73	42	1	37	1.2	32	1.5	29	1.8
		1200	69	0.5	62	0.8	56	1.2	51	1.5	47	1.8	43	2.1
		1400	84	0.6	76	1	71	1.3	66	1.7	62	2.1	58	2.5
AEW 390	40nb	800	54	0.4	44	0.7	35	1	28	1.3	22	1.6	17	1.9
		1000	75	0.6	64	0.9	56	1.3	49	1.7	42	2	37	2.4
		1200	95	0.7	84	1.1	76	1.5	69	2	63	2.46	57	2.9
		1400	115	0.8	104	1.3	96	1.8	89	2.3	83	2.9	77	3.4
AEW 3127	65nb	800	77	0.6	62	1	50	1.4	40	1.8	31	2.2	24	2.6
		1000	105	0.7	90	1.2	78	1.7	69	2.3	60	2.8	52	3.3
		1200	134	0.8	119	1.5	107	2.1	97	2.7	88	3.3	80	4
		1400	162	1	147	1.7	135	2.4	125	3.2	117	3.9	109	4.6
AEW 42	40nb	800	59	0.6	50	0.9	43	1.2	37	1.5	31	1.8	26	2.1
		1000	79	0.8	70	1.1	63	1.5	57	1.9	52	2.3	47	2.6
		1200	100	0.96	91	1.4	83	1.8	77	2.3	72	2.7	67	3.2
		1400	120	1.1	111	1.6	104	2.1	98	2.6	93	3.2	88	3.7
AEW 44	65nb	800	89	0.8	76	1.2	67	1.7	59	2.1	52	2.5	45	3
		1000	118	1	106	1.6	96	2.1	88	2.7	81	3.2	75	3.7
		1200	148	1.2	136	1.9	126	2.5	118	3.2	111	3.8	104	4.5
		1400	178	1.4	165	2.2	156	2.9	148	3.7	140	4.5	134	5.2
AEW 45	80nb	800	111	1	95	1.5	83	2.1	73	2.6	64	3.2	56	3.7
		1000	148	1.2	132	1.9	120	2.6	110	3.3	102	3.9	94	4.6
		1200	185	1.5	170	2.3	158	3.1	148	3.9	139	4.8	130	5.6
		1400	222	1.8	207	2.7	195	3.7	185	4.6	176	5.5	168	6.5
AEW 47	80nb	800	166	1.3	143	2.1	125	3	110	3.8	97	4.6	85	5.4
		1000	222	1.7	199	2.7	181	3.7	166	4.7	152	5.7	140	6.8
		1200	278	2	255	3.2	237	4.5	221	5.7	208	6.9	196	8.1
		1400	333	2.4	310	3.8	292	5.2	277	6.7	264	8.1	252	9.5
AEW 53	65nb	800	141	1.4	123	2.1	109	2.8	97	3.5	87	4.2	77	4.8
		1000	188	1.8	169	2.7	155	3.5	144	4.4	133	5.2	124	6
		1200	234	2.2	216	3.2	202	4.2	190	5.2	180	6.2	170	7.3
		1400	281	2.5	262	3.7	248	4.9	237	6.1	226	7.3	217	8.5
AEW 55	80nb	800	177	1.7	154	2.5	136	3.4	121	4.2	108	5	97	6
		1000	235	2.1	212	3.2	194	4.2	180	5.3	167	6.4	155	7.4
		1200	293	2.6	270	3.8	252	5.1	237	6.4	224	7.6	213	9
		1400	351	3	328	4.5	310	6	295	7.4	283	9	271	10.4
AEW EXPO-55	80nb	800	177	1.7	154	2.5	136	3.4	121	4.2	108	5	97	6
		1000	235	2.1	212	3.2	194	4.2	180	5.3	167	6.4	155	7.4
		1200	293	2.6	270	3.8	252	5.1	237	6.4	224	7.6	213	9
		1400	351	3	328	4.5	310	6	295	7.4	283	9	271	10.4

# AEW BLOWERS

## PERFORMANCE TABLE

### Water Cooled Series

MODEL	IN/OUT	SPEED	1000mmwc		2000mmwc		3000mmwc		4000mmwc		5000mmwc		6000mmwc		7000mmwc		8000mmwc		9000mmwc		10000mmwc			
			nb	R.P.M	m <sup>3</sup> /hr	BHP	m <sup>3</sup> /hr	BHP	m <sup>3</sup> /hr	BHP	m <sup>3</sup> /hr	BHP	m <sup>3</sup> /hr	BHP	m <sup>3</sup> /hr	BHP	m <sup>3</sup> /hr	BHP	m <sup>3</sup> /hr	BHP	m <sup>3</sup> /hr	BHP	m <sup>3</sup> /hr	BHP
AEW 57	100nb	800	248	2	215	3.2	191	4.4	170	5.6	152	6.8	135	8										
		1000	329	2.5	297	4	272	5.5	251	7	233	8.5	216	10										
		1200	410	3.1	378	4.8	353	6.6	333	8.4	314	10.2	298	12										
		1400	491	3.6	459	5.7	435	7.7	414	9.8	396	11.9	379	14										
AEW 510	125nb	800	354	2.6	308	4.3	273	6	243	7.7	217	9.4	193	11.1										
		1000	470	3.3	424	5.4	389	7.5	359	9.7	333	11.8	309	13.9										
		1200	586	3.9	540	6.5	505	9	475	11.6	449	14.1	425	16.7										
		1400	702	4.6	656	7.6	621	10.5	591	13.5	565	16.5	541	19.5										
AEW 512	125nb	800	441	3	393	5	356	7	325	9.1	297	11.1	273	13.1										
		1000	580	3.7	532	6.2	495	8.8	464	11.3	437	13.9	412	16.4										
		1200	720	4.49	671	7.5	635	10.6	604	13.6	576	16.7	551	19.7										
		1400	859	5.2	811	8.8	774	12.3	743	15.9	715	19.4	691	23										
AEW 65	100nb	800	270	2.1	243	3.3	222	4.5	205	5.7	190	6.9	176	8.2	163	9.4	151	10.6	140	11.8	130	13		
		1000	353	2.6	326	4.1	306	5.6	288	7.2	273	8.7	259	10.2	246	11.7	235	13.3	224	14.8	213	16.3		
		1200	437	3.1	410	4.9	389	6.8	372	8.6	357	10.4	343	12.3	330	14.1	318	15.9	307	17.8	297	19.6		
		1400	520	3.6	493	5.8	473	7.9	455	10	440	12.2	426	14.3	414	16.5	402	18.6	391	20.7	380	22.9		
AEW 67	100nb	800	404	2.7	364	4.5	333	6.3	307	8.2	284	10	264	11.8	244	13.7	227	15.5	210	17.3	194	19.2		
		1000	530	3.4	489	5.6	459	7.9	432	10.2	410	12.5	389	14.8	370	17.1	352	19.4	335	21.7	320	24		
		1200	655	4	615	6.8	584	9.5	558	12.3	535	15	514	17.8	495	20.5	477	23.3	461	26	445	28.8		
		1400	781	4.7	740	7.9	709	11.1	683	14.3	660	17.5	640	20.7	620	23.9	603	27.1	586	30.4	570	33.6		
AEW 610	125nb	800	539	3.3	486	5.7	444	8.2	409	10.6	379	13	351	15.5	326	17.9	302	20.4	280	22.8	259	25.3		
		1000	706	4.15	653	7.2	611	10.2	577	13.3	546	16.3	519	19.4	493	22.4	470	25.5	447	28.5	426	31.6		
		1200	874	4.9	820	8.6	779	12.3	744	15.9	713	19.6	686	23.3	660	26.9	637	30.6	614	34.2	593	37.9		
		1400	1041	5.8	987	10	946	14.3	911	18.6	880	22.9	853	27.1	827	31.4	804	35.7	782	40	761	44.2		
AEW 612	150nb	800	647	3.8	583	6.7	533	9.67	492	12.6	455	15.5	422	18.4	391	21.3	363	24.3	336	27.2	311	30.1		
		1000	848	4.7	783	8.4	734	12.09	692	15.7	656	19.4	622	23	592	26.7	563	30.4	537	34	512	37.7		
		1200	1048	5.71	984	10.11	934	14.5	893	18.9	856	23.3	823	27.7	793	32	764	36.4	737	40.8	712	45.2		
		1400	1249	6.66	1185	11.7	1135	16.9	1093	22	1057	27.18	1024	32.3	993	37.4	965	42.5	938	47.7	913	52.8		
AEW 78	125nb	800	609	3.4	559	6.1	521	8.7	490	11.4	461	14	436	16.7	412	19.4	391	22	370	24.7	351	27.4		
		1000	791	4.3	741	7.6	703	10.9	672	14.3	643	17.6	618	20.9	594	24.2	573	27.6	552	30.9	533	34.2		
		1200	973	5.1	923	9.1	885	13.1	854	17.1	825	21.1	800	25.1	777	29.1	755	33.1	734	37.1	715	41		
		1400	1155	6	1105	10.7	1067	15.3	1035	20	1007	24.6	982	29.3	958	33.9	937	38.6	916	43.3	897	47.9		
AEW 710	150nb	800	761	4.1	699	7.4	652	10.7	612	14	577	17.4	545	20.7	515	24	488	27.4	463	30.7	438	34		
		1000	988	5.1	927	9.3	879	13.4	839	17.6	804	21.7	772	25.9	743	30	716	34.2	690	38.4	666	42.5		
		1200	1216	6.1	1154	11.1	1107	16.1	1067	21.1	1032	26.1	1000	31.1	971	36.1	943	41	918	46	894	51		
		1400	1444	7.2	1382	13	1334	18.8	1295	24.6	1259	30.4	1227	36.3	1198	42.1	1171	47.9	1145	53.7	1121	59.5		
AEW 712	150nb	800	929	4.78	862	8.77	810	12.7	767	16.75	728	20.7	694	24.7	662	28.7	632	32.7	604	36.7	578	40.6		
		1000	1203	5.98	1135	10.9	1083	15.9	1040	20.9	1001	25.9	967	30.9	935	35.9	905	40.8	877	45.8	851	50.8		
		1200	1476	7.18	1408	13.1	1357	19.1	1313	25.13	1275	31.12	1240	37.1	1208	43	1178	49	1150	55	1124	61		
		1400	1749	8.38	1681	15.3	1630	22.3	1586	29.3	1548	36.3	1513	43.2	1481	50.2	1451	57.2	1423	64.2	1397	71.2		
AEW 812	150nb	800	1257	8.4	1186	13.6	1132	18.8	1086	24	1046	29.2	1010	34.4	977	39.6	946	44.9	917	50.1	889	55.3		
		1000	1613	10.5	1543	17	1489	23.5	1443	30	1403	36.5	1367	43	1333	49.5	1302	56.1	1273	62.6	1246	69.1		
		1200	1970	12.6	1900	20.4	1845	28.2	1800	36	1760	43.9	1723	51.7	1690	59.5	1659	67.3	1630	75.1	1602	83		
		1400	2327	14.4	2256	23.8	2202	32.9	2157	42	2116	51.2	2080	60.3	2047	69.4	2016	78.5	1986	87.6	1959	96.8		

## APPLICATIONS

- **Water Treatment Plants** for back washing of filter/ mixed beds.
- **Effluent Treatment Plants** for diffused aeration & agitation of effluent/ Sewage.
- **Cement Plants** for Blending, Aeration, Fluidization, Conveying.
- **Aquaculture** for maintaining the dissolved oxygen level.
- **Chemical Plants** for supplying of process air.
- **Electroplating Plants** for oil free air agitation of electrolyte.
- **Paper Plants** knife edge coating, drying, conveying, vacuum pickup.
- **Pneumatic Conveying** Vacuum, pressure & combination conveying of cereals, cement, husk, baggase, granules, powders & other similar materials.

## Spare Parts & Accessories



Rotor Set



Timing Gear

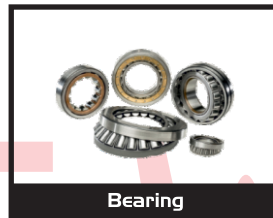

Bearing



Oil Seal



Base Frame



Pressure Gauge



Air Filter

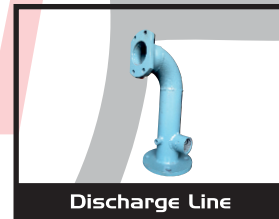

Discharge Line



Suction Silencer



Flanges



Non-Return Valve



Pressure Relief Valve



# BLOWERS

## Positive Displacement Blowers

*We Produce The Shape Of Progress*



@AEW Blowers

Aakash Engineering Works

**Goa Off.:** Simplisol Technologies Pvt. Ltd.  
M-39, Phase-III-B Verna Indl. Estate, Verna  
Salcette, Goa-403722 | Ph No.: 8007120501

**Telangana Off.:**  
SVP Engineers Pvt. Ltd.  
2/52/A, G/F, Chandanagar, Hyderabad, K,V  
Rangareddy-500050 | Ph No.: 7000163520  
E-mail : svpengeerspvtlimited@gmail.com

**Factory Address :** Kh. No.32/7, Near Metro Pillar No.779,  
M.I.E. Part-A, Bahadurgarh, Distt. Jhajjar Haryana- 124507  
**Ph.:** +91-7988313526, 9466675482  
**E-mail :** aewblowers@gmail.com | ahlawatb@yahoo.co.in  
**E-mail :** info@aewblowers.com | aewblowers@zohomail.in  
**Website :** www.aewblowers.com

**Maharashtra Off.:** Green Enviro Plastic Products  
Flat No. 404, Vastuship, HSG Society, Charoli, Bhosari,  
Pune - 412105 | Mob.: 7276798357, 7249489485

**Gujarat Off.:** Nextgen Envirotech  
D-65, Grand Vishala Indl. Estate, Near Odhav  
Ring Road, Circle, Odhav, Ahmedabad - 382415  
Mob.: +91-7069015501, 7990166244